



INSTALLATION INSTRUCTIONS

Accessory
PLOW PUSH TUBE
 P/N 0SL70-HL5-A00
PLOW BLADE
 P/N 0SL76-HL5-A00

Application
SXS520M2

Publication No.
WII 17623
 Issue Date
December 2020

Honda Dealer: Please give a copy of these instructions to your customer.

PARTS LIST

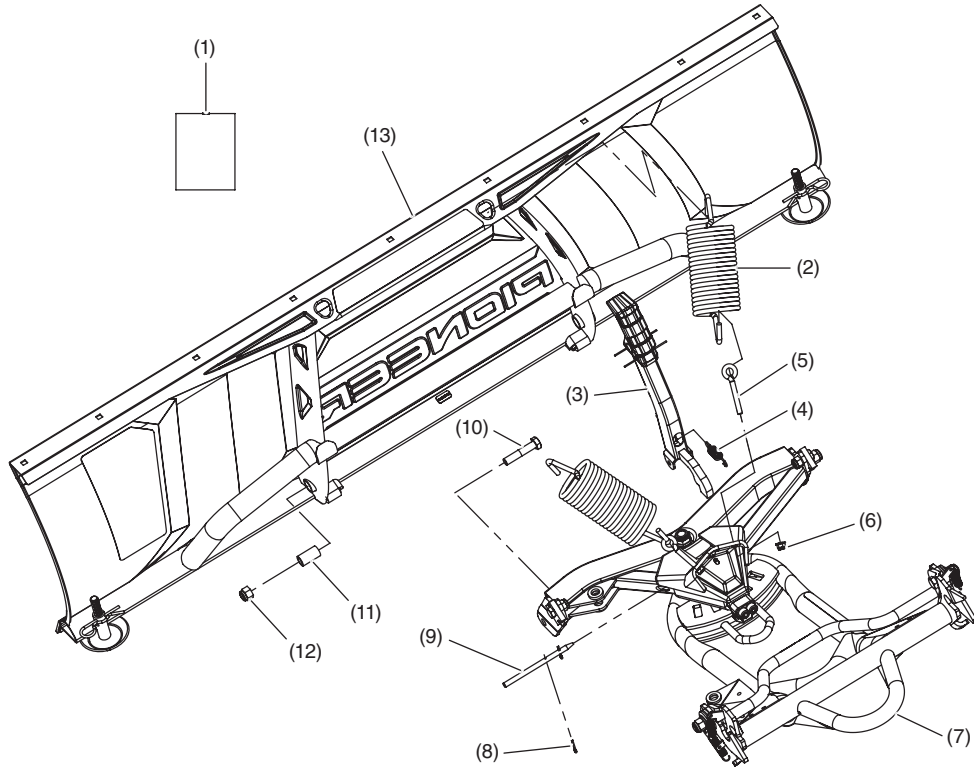

No.	Description	Qty
(1)	Installation Instructions URL	1
(2)	Large Spring	2
(3)	Handle	1
(4)	Handle Spring	1
(5)	Eye Bolt	2
(6)	12 mm Hexagonal Nylon Nut	2
(7)	Plow Push tube	1
(8)	Cotter Pin	2
(9)	Handle Pivot	1
(10)	19 x 60 mm Hexagonal Bolt	2
(11)	Blade Pivot Sleeve	2
(12)	19 mm Hexagonal Nylon Nut	2
(13)	Plow Blade	1

TOOLS REQUIRED

Long Nose Pliers
 Ratchet
 Torque wrench
 19 mm Socket Hex
 12 mm Socket Hex
 17 mm Socket Hex

TORQUE CHART

Item	N-m	kgf-m	lbf-ft
19 x 60 mm Hexagonal Bolt	83	8.5	61
12 mm Hexagonal Nylon Nut	n/a	n/a	n/a
17 x 30 mm Hexagonal Bolt	48	4.9	35

INSTALLATION

1. Insert the handle spring in the hole of the handle.

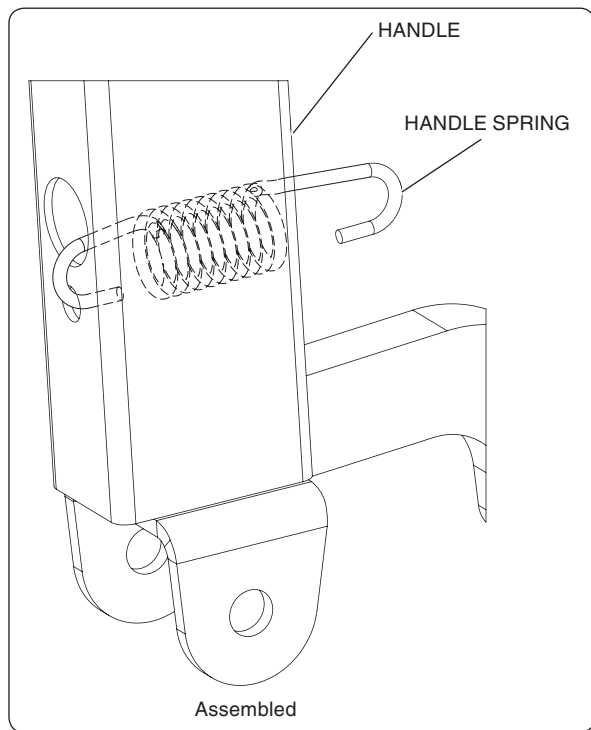
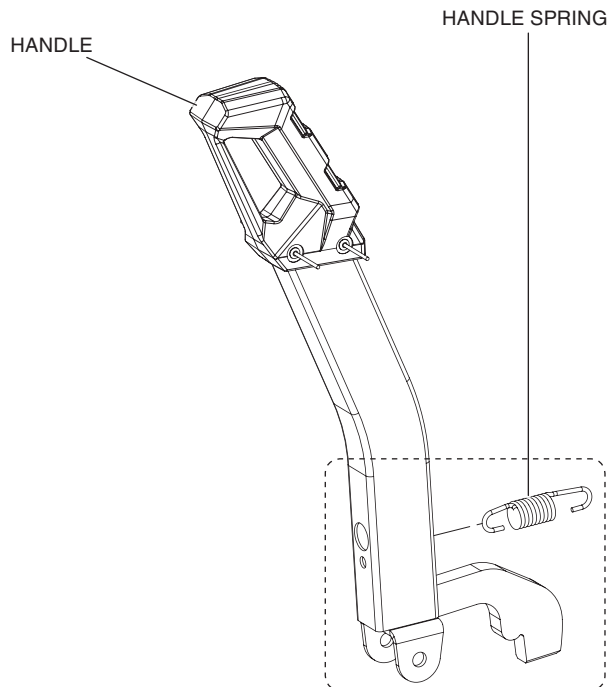

2. Align the holes of the handle with the holes of the plow push tube pivot. Insert the handle pivot on the side of the plow push tube pivot and make it pass through all four holes including the plow push tube pivot and the handle. Then under the plow push tube pivot, insert the cotter pins in the holes of the handle pivot.

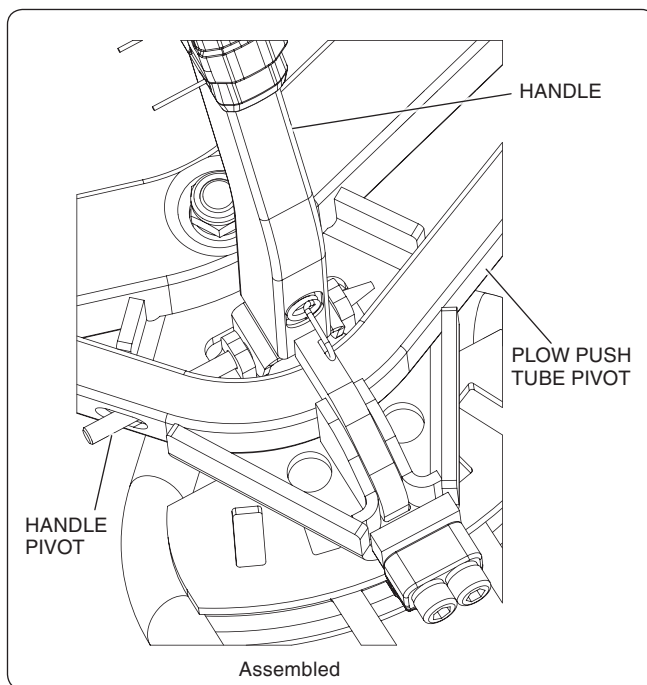
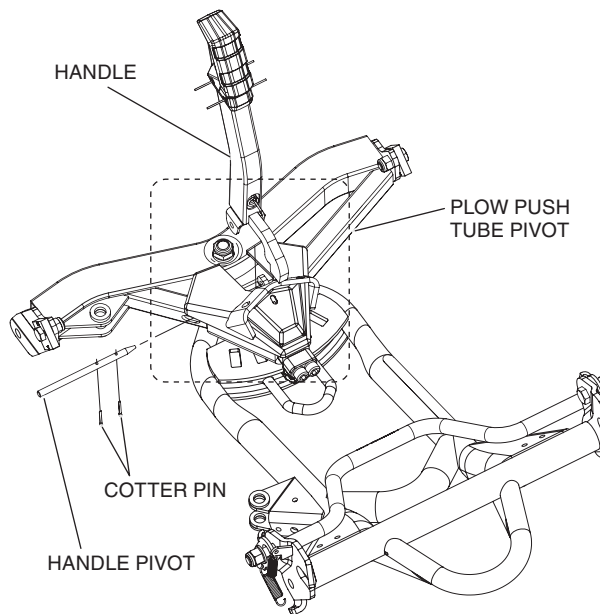

3. Install the other end of the handle spring in the hole of the plow push tube pivot.

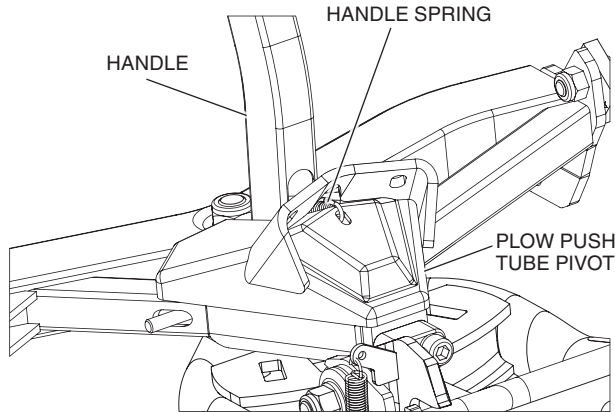

4. Position the plow blade face down on the floor or on a table (as shown). Insert the blade pivot sleeves in the holes of the plow blade. Position the pivot of the plow push tube in the middle of the plow blade. Insert the 19 x 60 mm hexagonal bolts in the push tube pivot holes and through the blade pivot sleeves, then secure with the 19 mm hexagonal nylon nuts. Tighten the bolts to the values specified in the TORQUE CHART.

NOTICE: Assemble the nuts so that they are on the exterior side to prevent damage in case of impact.

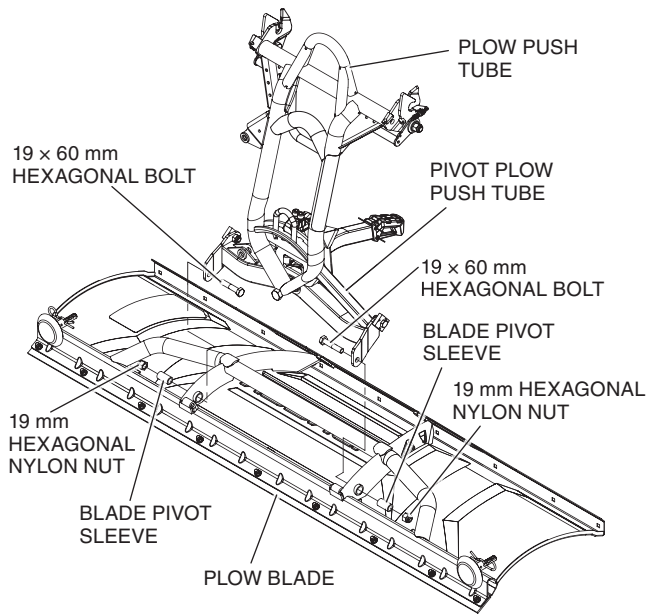

5. Install large spring onto plow blade and into the supplied eye bolts. The threaded end of the eyebolt is then installed in the holes of the pivot plow push tube and secure with the 12 mm hexagonal nylon nuts.

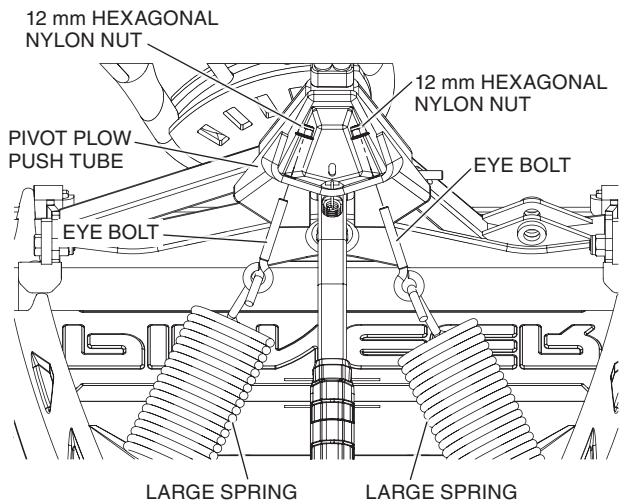
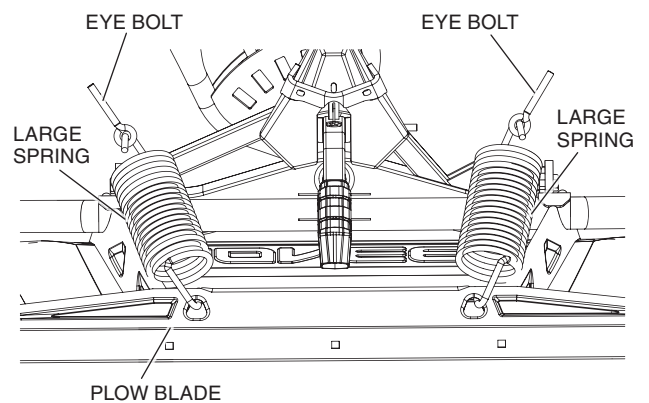
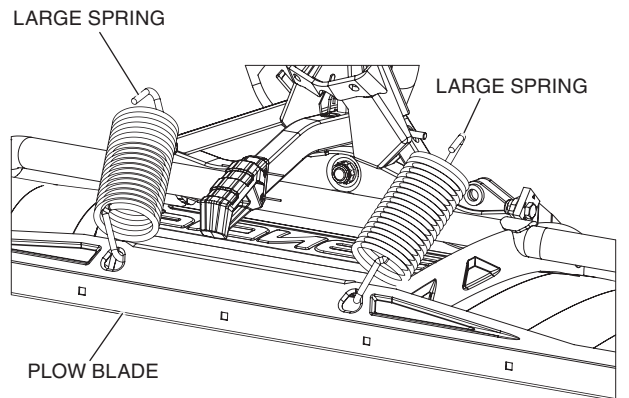

- Position the plow system in front of the vehicle. Lift the rear of the plow system by the lock handle. This will allow both U-plate hooks to open-up at the same time.

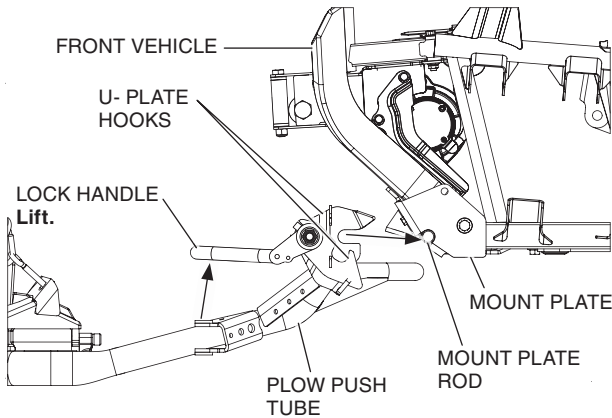

- Position the plow system so the U-plate hooks of the plow push tube are completely around the rods on each side of the mount plate. Release the lock handle and make sure both U-plate hooks have remained completely around the rods on each side of the mount plate.

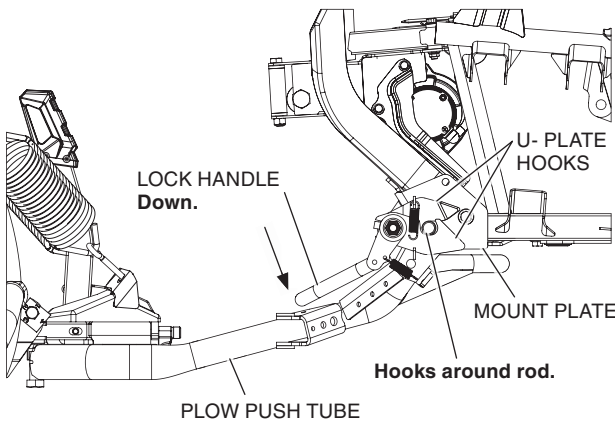

- Install the winch hook on the rod of the plow push tube.

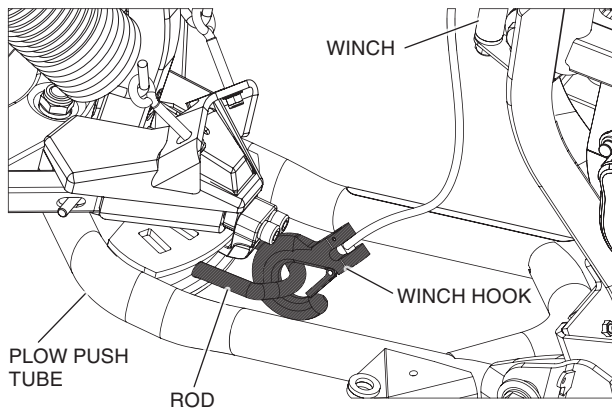

ADJUSTMENT

- To adjust the blade's lateral angle, first raise the plow system (about 16 off the ground) with the vehicle's winch. Pull the handle towards the blade so the plow blade can rotate freely.

CAUTION

Breakage of the winch cable may occur at any time. Never leave your feet under the blade in case the plow system falls. This could cause serious injury.

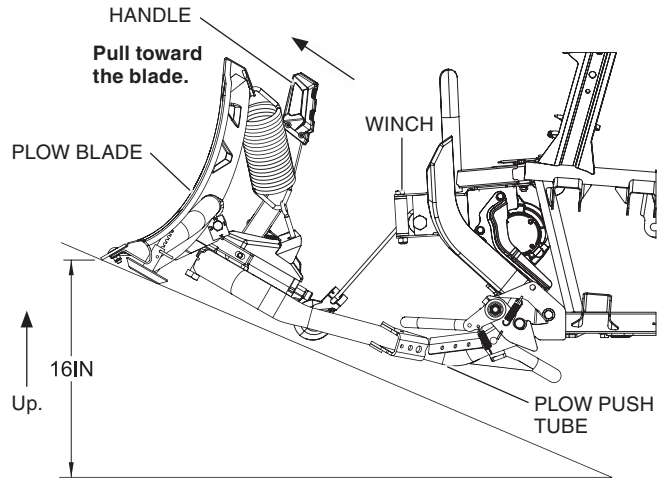

- Rotate the blade to the desired angle. Release the handle and make sure that the lock fits into one of the five angulation holes of the push tube.

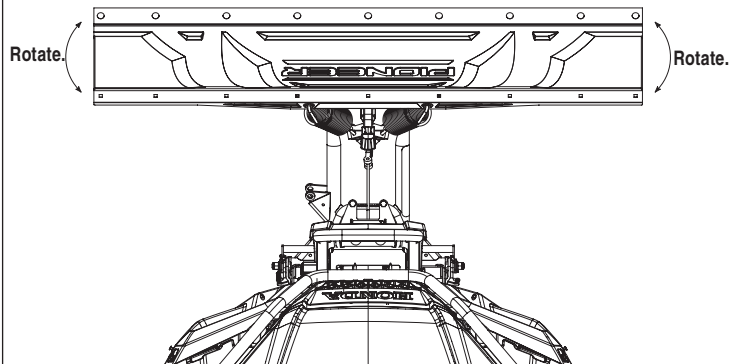

- To adjust the blade's tilt, first remove the large springs to release the tension on the plow blade. Loosen the 17 × 30 mm hexagonal bolts and the 17 mm hexagonal nuts on each side so that the setting blocks may rotate freely. Tilt the blade to one of the four possible positions (1-2-3-4). Tighten the bolts and the nuts to the values specified in the TORQUE CHART. Reinstall the large springs (see step 5).

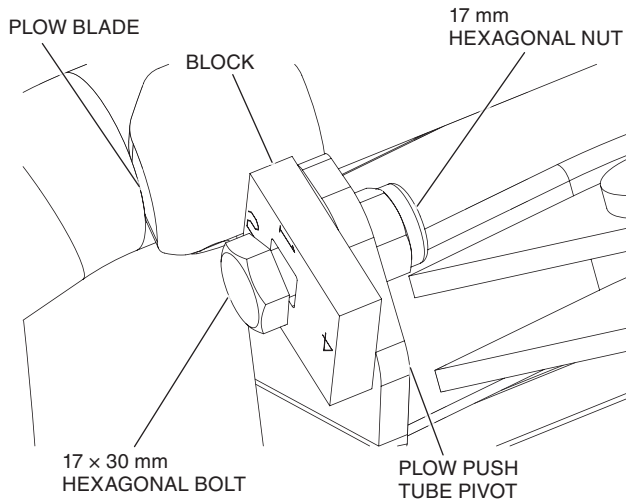

The plow blade is designed to flip forward when it hits an obstacle. Once passed the obstacle, the plow blade will reposition itself on its own.

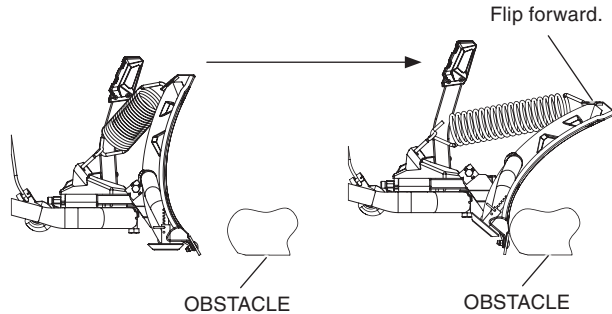

- This feature can be adjusted by tightening or loosening the 12 mm hexagonal nylon nut on the plow push tube pivot. To increase resistance, tighten the nut. To decrease resistance, loosen the nut.

Minimum tension: when the spring's coils just start to come off.

Maximum tension: when the nuts are fully threaded on the eye bolts.

